

CMLA

Pro IP Camera



CMLA5XRL200

- Pro IP Dome
- 1/2.8" SONY Starvis Back-illuminated CMOS Sensor
- H.265+/H.265/H.264+/H.264 Compression Method
- 2.7-13.5mm Motorized Lens
- IR Distance 25M Max.
- With Internal POE

www.longse.com

Data Subject To Change Without Notice

SPECIFICATION	
Model NO.	CMLA5XRL200
Camera	
Image Sensor	1/2.8" SONY Starvis Back-illuminated CMOS Sensor
Resolution	2MP 1080P
Effective Pixels	1945(H)*1097(V)
Compression	H.264/H.264+/H.265/H.265+/JPEG/AVI /MJPEG
Audio Compression	G711A/U,AAC
TV System	PAL/NTSC
Electronic Shutter Time	Auto: 1/3-1/100000Sec
Minimum Illumination	Color: 0.001 Lux @ (F1.6, AGC ON),B/W: 0 Lux with IR
S/N Ratio	60dB
Scanning System	Progressive
Video Output	Network
Reset Button	Optional
Lens	
Focal Length & FOV	2.7-13.5mm Motor Zoom, horizontal FOV 103°—29°, vertical FOV 54°—16°, diagonal FOV 124°—33°
Focus Control	Auto
Lens Type	Auto
Aperture	F1.6 - F3.3
Pixels	2MP
Night Vision	
Infrared LED	42μ x 2PCS
Infrared Distance	25M
IR Status	Auto Control
IR Power On	Smart, Manual & Timed mode
Network	
Ethernet	RJ-45 (10/100Base-T)
Wireless	N/A
Protocol	TCP/IP,IPv4/v6, ICMP, HTTP, HTTPS, FTP, DHCP, DNS, DDNS, RTP, RTSP, RTCP, PPPoE, NTP, SMTP, UDP, SNMP,Qos,802.1x
ONVIF	Support ONVIF 19.12(Profile S/T/G)
P2P	YES
POE	Internal, Support IEEE 802.3af
Video Delay	0.3S (Within the Lan)
Main Stream 1	2304*1296@30fps
Main Stream 2	1920*1080@60fps
Main Stream 3	1280*720@60fps
Sub Stream 1	1920*1080@30fps 1280*720@30fps
Sub Stream 2	720*480@30fps
Sub Stream 3	352*288@30fps
Tri Stream	1280*720@30fps 720*480@30fps 352*288@30fps
IE Brower	IE8-11, Google Chrome, Firefox , Mac Safari
Smart Phone	iPhone, Android
AI Function	
Intelligent Analysis	Face Detection,Intrusion Detetion(based on human and Vehicle Detection), Line Cross Detetion(based on human and Vehicle Detection), Loiter Detetion, Itople Gather Detetion(based on human detection),Motion detection based on human detection
Camera Features	
Day/Night	Color/ B&W (IR-CUT)
Image Config	Saturation/Brightness/Contrast /Sharpness, Mirror, 3D NR , White Balance, Anti Flicker, Video Tampering, HLC, Distortion
Full Color	N/A
Corridor Pattern	Support
Defog Mode	Support
ROI	Support
BLC	Support
WDR	120dB
Motion Detection	Support(support enable the detection based on human movement only)
Privacy Masking	3 Rectangular Zone
Recording Mode	NVR/CMS/Web
Language	Chinese Simplified, Chinese Traditional, English, Bulgarian, Polish, Arabic, German, Russian, French, Korean, Portuguese, Japanese, Turkish, Spanish, Hebrew, Italian,Nederlands,Czech, Vietnamese
Interface	
Audio	Optional 1 Built-in MIC
Alarm	Optional 1 Channel Input/Ouput
SD Card Slot	Optional Internal, Support Max 1TB,Built in 4G Storage
RS485	N/A
General	
Housing	Metal (Ring Plastic) , IP67
Anti-cut Bracket	NO
IR Cut Filter	YES
Operation Temperature	-20°C ~ +60°C RH95% Max
Storage Temperature	-20°C ~ +60°C RH95% Max
Power Source	DC12V±10%, 700mA
Dimension	φ136 x 148(H)mm
Weight	1700g

www.longse.com

Data Subject To Change Without Notice

Technical Specifications

Model	CMLA
Material	Aluminum & SECC & PC
Dimension(WxHxD)	Φ136x 148mm
Weight	set with packaging 1.7kg
Color	Sand Grain White
Operating Temperature	-20°C ~ +60°C
Humidity	< 95% RH
Optional accessories	B245

Dimensions (mm)

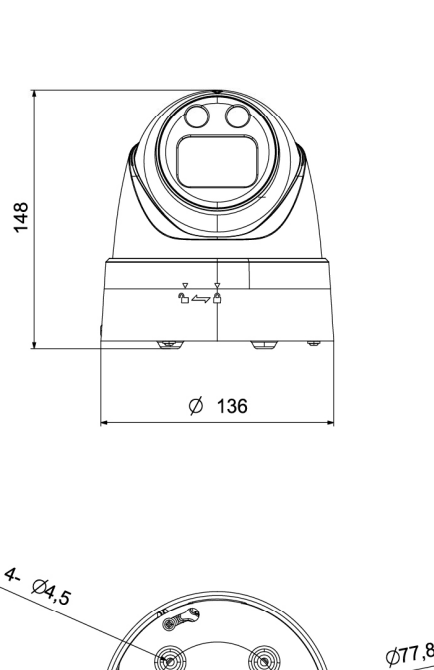

www.longse.com

Data Subject To Change Without Notice